

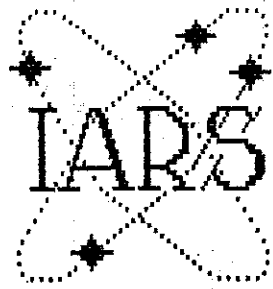

# THE PROPAGATOR



## ILLAWARRA AMATEUR RADIO.SOC.INC.

MONTHLY NEWSLETTER OF THE ILLAWARRA AMATEUR RADIO. SOC. INC.  
VOLUME - 86 , NUMBER : 9

OCTOBER 1987.

REGISTERED BY AUSTRALIA POST PUBLICATION NUMBER : NBH - 1491.

MEETINGS ARE HELD ON THE SECOND TUESDAY OF EACH MONTH,  
(EXCEPT JANUARY) AT 7.30.PM. AT THE STATE EMERGENCY SERVICES,  
BUILDING, IN MONTAGUE STREET, NORTH WOLLONGONG.

VISITORS ARE MOST WELCOME TO ATTEND THE MEETING'S.

### COASTGAURD RADIO TALK

September Monthly meeting. The September meeting was held on the 8/9/87 and the flu which has been raging in Wollongong kept attendance down to abt 26 or so members.

Flotilla Commander Lloyd Mills from the Coastguard attended the meeting and gave a talk on Coastguard Radio. Operators for this service are needed and

any Club member willing and able to perform single relief watches or join a regular roster would be welcome. Members can ring Lloyd Mills on home phone 742871 or at the Coast Guard station at Port-Kembla on ph: 744455.

A meat raffle was held at the meeting and raised funds for the club. Also a new member who joined the Club at the September meeting was Ken Grimm VK2XHN.

\*\*\*\*\*

Peter VK2XAN reported that he had spoken to a meeting of the blind society and the Club may receive a request for assistance and more information. The meeting closed with the usual tea & bikies.

\*\*\*\*\*

### AYRES ROCK CONVENTION

We dont know what the attraction iis but both our President and Vice pres are heading for Ayres Rock, Bill by coach and Keith by fore runner. Both will be away for the October meeting and Ray VK2XCC says he might go as well.

### REMARKABLE RECORD

September Committee Meeting. A well attended meeting was held and a number of subjects were discussed.

Future possible variations of our repeater Sites were discussed also results of field tests on 70.cm

Graeme VK2CAG reported some conflict between his post as chairman of the repeater committee and his business activities which have recently been extended.

John VK2XGJ has agreed to fill Graeme's

position as Repeater Committee Chairman and the Club Committee endorsed this change.

Graeme has a remarkable record of construction and maintenance of the Clubs Repeaters.

This was recognised several years ago when the Club made Graeme one of the few Life Members we have.

Tony VK2ENX mentioned some equipment which may be available for purchase as a start for a Club Station.

# SILENT KEY

## FOR

### ++++VK2 BAZ ++++

It is with sadness that we have to report on the death of a fellow amateur, friend and club member, VK2BAZ.

Although he was known by club members as "Baz" he was christened THOMAS BASIL RYAN. Baz was born in Wollongong on June 4th 1916.

He met Mary at a dance being held in the Southern Cross hall, and after a courtship talked Mary into becoming his wife.

Baz joined the R.A.A.F. as a mechanic, and served overseas in England for 1 year and also in Egypt for 2 years.

Whilst as a mechanic in the R.A.A.F. he worked on the famous "G" for GEORGE bomber aircraft that can now be seen in the Canberra War Museum.

On returning to Australia, and leaving the R.A.A.F; Baz carried on with his occupation as a mechanic working around the Wollongong area until his retirement.

He became interested in Amateur

radio a few years ago, and after studying hard at home for a few months sat and passed his Novice exam, and he was given the callsign VK2KTA.

He joined the Illawarra Amateur Radio Club on the 13th July 1986, and sat for the full call exam which he passed and got his new callsign VK2BAZ.

Baz passed away peacefully during the night at home on the 16th September 1987.

He died from a coronary attack, and as we keep a "SILENT KEY" for you Baz, your club mates send their sympathy to your wife Mary, and your two sons, Paul and Robert. Also to your two grandchildren and wish them all 73's for their futures.

VK2PZY (Dave).

### WANTED

Wanted ONE Mast section, 6. foot long triangular section parallel side, to complete mast to required height.

Contact:  
VK2EJH · Jim  
on(042) 84-9317

### WANTED

WANTED TO BUY:

KENWOOD 520.S

DIGITAL READ OUT

PLEASE:

Phone on (046) 30-9158.  
and ask for Vic.

### WANTED

WANTED:

AN AMATEUR OPERATOR OR SECOND OP WHO SPEAKS CZECHOSLOVAKIAN. A CZECH HAM OPERATOR IS TO VISIT WOLLONGONG ON A YACHT AND SOMEONE TO SPEAK HIS LANGUAGE WOULD BE A NICE GESTURE. Phone 56-2213. Sec. UK2JTB Tom Brown.

### FOR SALE

FOR SALE: THE I.A.R.S. inc. STILL HAS THE WIND GEN USED AT MT. MURRAY FOR SALE.

INTERESTED PARTIES SHOULD CONTACT :  
UK2XGJ-JOHN on 146.850.  
or on PACKET one 147.575

# Tom retires from Tower

After nearly 12 years with the Company, Tom Potter recently became the first Federation member to retire from Tower Colliery.

To mark the occasion and reflecting the esteem in which he is held, Tom received an engraved mug and a wallet containing \$1000 from all his workmates.

Tom worked as a boilermaker for 32 years in outside industry before starting at Old Bulli, then transferred over to Tower. He has a son and three brothers who also work in coal at Muswellbrook No. 2 and South Bulli.

Tom has spent most of his time with the Company driving shuttle cars and had a clean sheet up until his last week, when he damaged his first miner cable. Never mind Tom, we won't tell anybody.

In retirement, he plans to spend his time travelling, including a trip to Japan to meet friends he has come to know through his hobby as an amateur radio enthusiast.

Everyone at Tower and other workmates throughout the Company extend their best wishes for the future to Tom and his family.

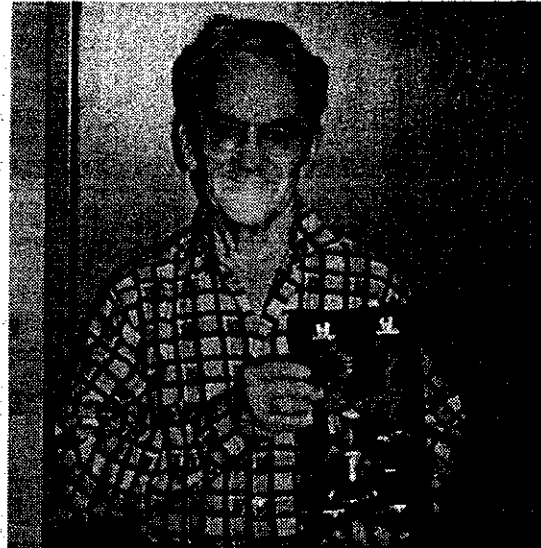

● Tom Potter VK2VOD

WHICHEVER WAY YOU LOOK AT IT  
YOU CANT GO PAST  
**MARINA GARAGE**  
FOR SERVICE CALL IN AND SEE  
**PETER CHIECO**

For Your :-

- \* Electronic tune up \* Wheel balancing
- \* Front end alignment \* Brakes
- \* And also Rego Checks.

146 PRINCES HIGHWAY, CORRIMAL

PHONE: 84 5650

## GRAND FINAL SCUTTLES PICNIC

Our social director Ray organised a picnic for the Club at William beach park for Sunday 27/09/87 but this clashed with the League Grand Final and attendance was limited to Ray & Peg, Tony VK2ENX & Family and VK2KIH Seppo and Family.

-----\*\*\*\*-----

## WANTED

WANTED: PACKET SOFTWARE TO RUN ON IBM XT OR COMPATIBLE.

Please contact VK2ENX

TONY or

Phone on (042) 28-5296.

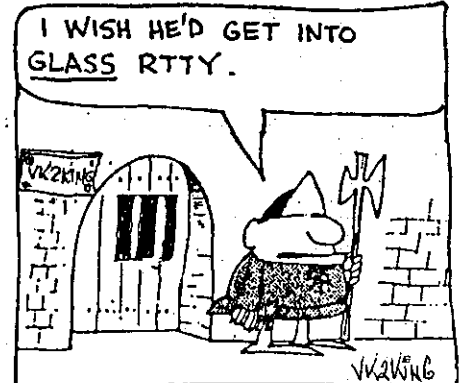
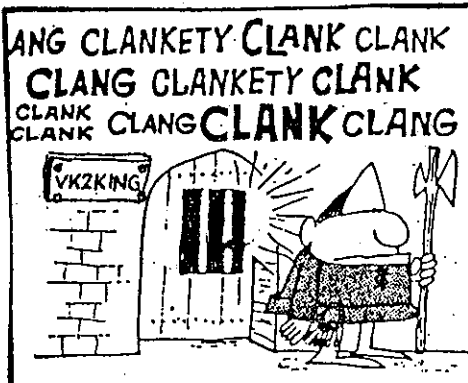

# ON THE NET

-----\*\*\*\*\*-----  
 30th August 1987.

VK2PHD-RAY, Co-ordinator.  
 VK2NNJ-JOHN, VK2MT-ROB,  
 VK3CMH-MARTIN, VK2JNC-  
 NEIL, VK2EMV-MORRY.

13th September 1987.

VK2MT-ROB Co-ordinator,  
 VK2EBI-KEVIN, VK2PZY-DAVE  
 VK2ERH/5-RALPH, VK2PHD-RAY  
 VK2DFL-DAVE, VK2FDU-PAUL,  
 VK2EMV-MORRY.

20th September 1987.

VK2PZY-DAVE, Co-ordinator,  
 VK2MT-ROB, VK2EBI-KEVIN,  
 VK2EMV-MORRY, VK2PHD-RAY,  
 VK2DFL-DAVE, VK2NH-DAVE.

27th September 1987.

VK2PHD-RAY, Co-ordinator,  
 VK2PZY-DAVE, VK2MT-ROB,  
 VK2EBI-KEVIN, VK2ERH/5-  
 RALPH, VK2EMV-MORRY.  
 VK2EPH-PAT, VK2DFL-DAVE,  
 VK2JT/P-JOCK.

-----\*\*\*\*\*-----

— FOR —  
**COURTESY TO**  
**AMATEURS AND**  
**VALUE**  
**IN**  
**OUR AREA**  
**NOT USUALLY**  
**SEEN ELSEWHERE**

WE RECOMMEND!!!!

**CAYIONS**

11. MOLLOY STREET, BULLI.  
 PHONE: 042-84-6838

TO ALL OUR CLUB  
 MEMBERS.

Dont make expensive mistakes by buying blind  
 What should you expect as a minimum when  
 purchasing an IBM compatible?

- \* Dual speed 4.77MHz & 8MHz
- \* 8088-2 Processor
- \* Fully socketed Mother Board
- \* Socket provided for 8087 arithmetic chip
- \* Eight Expansion slots (2 should only be occupied)
- \* Extra sockets for ROM's
- \* Minimum 640K on Mother Board
- \* 135w Power Continue output
- \* Built in cooling fan
- \* Centronic parallel printer port
- \* 2 RS-232 serial Communication port ( you will probably end up with a Modem & Mouse or A/D card etc )
- \* Joystick Port
- \* Dual floppy Controller
- \* Battery backed clock/calendar
- \* Legal Bios eg. ERSO
- \* 2 Quality Floppy Japanese Disk Drives as used in Sperry, IBM, Olivetti etc .
- \* An on site Warranty & Insurance must be available from Computer Shield or Hills Industry (Nationally protected). If these companies dont offer maintenance on the machine you are purchasing then forget it, Companies only offer maintenance contracts on machines they believe are reliable.

**PHONE J.C.E. SOLUTION SELLERS.**

We have been selling Computers since 1979 as a family run business where Personal Service is a —(PRIORITY)—

Mon - Fri 7.30-9.30pm. Phone: <042>61-5451.  
 OPEN FOR BUSINESS ALL WEEK END

CALL-BACKS ON VK2AMW/P

-----\*\*\*\*\*-----

9th August 1987. VK2TPH	6th September on VK2AMW/P
VK2EXN - VK2EMV - VK2CAG	-----*****-----
VK2KCV - VK2MT/P- VK2XGJ	VK2EXN - VK2CAG - VK2BIT-
VK2BES.	VK2XGJ - VK2KHE - VK2MT -
And on 80 metres:	VK2ENX - VK2EMV.
VK2DFL- VK2BIT - VK2AXI	And on 80 meters:
VK2IU - VK2PHD - VK2EMV	VK2DFL - VK2PHD - VK2ENX.
VK2ENX - VK3DOV. #. VK3CMH.	-----*****-----

# MEMO

Club XMAS Party  
will be held at the  
CORDEAUX - DAM  
on the 13th DEC 87  
See you all there.

Social  
Director  
VK2XCC



RAY

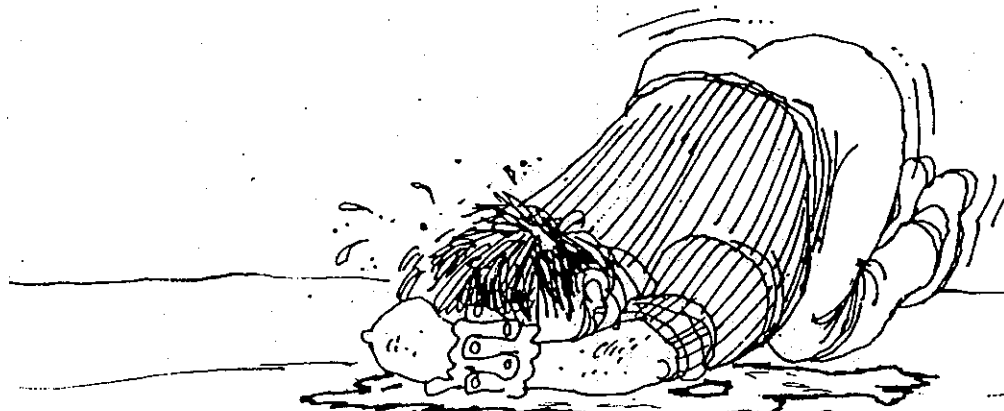

I AM STILL WAITING !!!  
FOR THOSE PROJECTS. (THE EDITOR)

—FOR—  
**C**OURTESY TO  
**A**MATEURS AND  
**V**ALUE  
**I**n  
**O**UR AREA  
**N**OT USUALLY  
**S**EEN ELSEWHERE

WE RECOMMEND!!!!

## CAVIONS

11. MOLLOY STREET, BULLI.  
PHONE: 042-84-6838

TO ALL OUR CLUB  
MEMBERS.

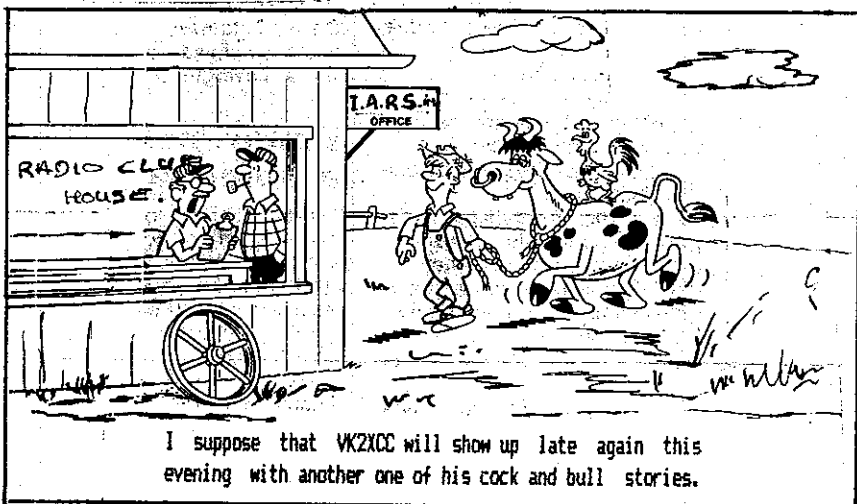

I suppose that VK2XCC will show up late again this evening with another one of his cock and bull stories.

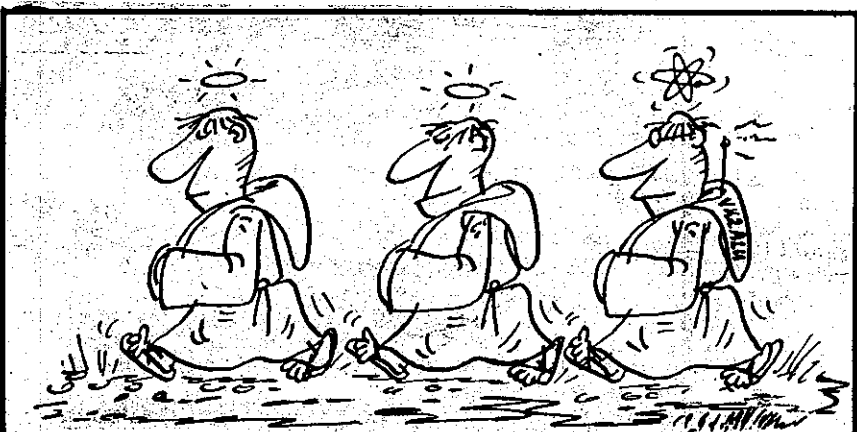

## A BEHIND THE SCENES LOOK AT THE 1986 JAMES HARDIE 1000

The Sydney television station, ATN 7, has had a long association with the annual endurance race for touring cars that is held on the public road covering Mount Panorama in Bathurst on the first Sunday of October. It has proved, above all, to be mutually beneficial. As ATN's coverage has become more sophisticated, the motor race has grown in stature & it is ranked only second in importance to the 24 hour race for touring cars held at the Spa track in Belgium. The race is now included as a round of the World Touring Car Championship, a new series which kicked off this year. ATN's coverage is said to command the largest TV audience in the world for a touring car event. For example, last years race was directly relayed, in full, to 38 Australian TV stations as well as TVNZ. Overseas customers included the BBC, while videotape packages were screened throughout Europe, the Middle East, Asia & the US. Two weeks before raceday, the first crew of ATN's engineers & technicians arrive to begin laying the groundwork for a coverage that last year involved 220 staff & cost \$1,000,000. Now that it's time for this years race, a look behind the scenes might be of interest to you to help you appreciate the huge amount of technical expertise & equipment that goes into providing the coverage you see at home. The following is what was used last year. This year's coverage will be basically the same.

ATN presented nearly 12 hours of unbroken coverage. To do this, it needed eight mobile vans plus equipment control buildings (it used some TEN 10 & AAV mobile facilities), 28 cameras (including 3 from race cars), 2 helicopters, 17 videotape machines, character generator & graphics equipment, digital video effects & ATN's new computer scoring system, Racescore. Apart from that, technicians layed kilometres of audio & vision cable throughout the pits & the circuit. Also, much use was made of RF links, while one of the helicopters was a designated camera unit, acting as a backup to chopper used to relay the pictures from the Racecam cars. Another camera was used to cover the action in the pits. This used a portable back-pack microwave link which relayed its signal to the 7 tower. The programme sound was mixed in stereo.

**VISION SWITCHING:** 19 cameras were strategically placed around the circuit & combined with aerial coverage from the ATN Choppercam provided a continuous trackside coverage of the race progress.

-THE QUARRY (ATN OB 2) - 5 cameras numbered 4 to 8 in sequence from GTX Bend through BP Cutting & the Quarry area to Reid Park were switched & controlled thru' this van.

-CASTROL TOWER (TEN OB 1) - 8 cameras, numbered 9 to 16 from Castrol Curve around Skyline, the Dipper & the Esses to Forest Elbow.

-UPSTREAM (TEN OB 2) - This van switched the outputs of "The Quarry" van & the "Castrol Tower" van. In addition, another 3 cameras numbered 1 to 3, a remote control camera, number 17, was suspended from a crane over Conrod Straight & the ATN Choppercam were switched thru' this van. The output of this van went to ATN OB 1.

-PITS (ATN OB 3) - This van switched 4 cameras, numbered 20, 21, 22 & 28. Camera 20 was a portable unit working the Pit row & used a triax cable system that plugged into a number of points along the Pit Armco fence. A commentator worked with this camera using a radio mic & a wireless communications system. Camera 21 was also a portable unit, cabled into "Downstream Control" for the pre- & post-race segments. During the race it became a fixed camera in Pit 24 to cover interviews & operate alongside camera 22. Camera 28 was a portable camera, microwave linked to the 7 tower & then cabled to the van.

-SLO MO Van - This videotape area (based around Sony BVU machines) recorded any incidents from the following sources: Quarry, Quarry Isofeed, Castrol, Castrol Isofeed, Upstream & Racecam. Replay from this area was via a single output designated "Slo-Mo". Monitoring of all inputs in the Slo-Mo area was difficult & relied on prompts from any of the five directors (in the different vans) to help locate a possible replay.

-UPDATE Van - This videotape area edited the hourly update segments from both 1" & Betacam material. Replay from this area to "Downstream" Control was via a single output, designated "update".

-DOWNSTREAM (ATN OB 1) - This van was the final assembly & control area for the telecast. This van combined the sources from Upstream Control, Pits, Racecam, Slo-Mo & Update VTR Van & cameras 18, 19 & 23. Camera 21 was also cabled to this van for pre- & post-race segments. An NEC E-Flex was also operated from Downstream control to introduce replays & updates. You don't know what an E-Flex is?... it is a real high-tech piece of equipment. It's the device that makes the picture "explode" into thousands of bits & back together again (TCN 9 use that function on their commercial break play-offs on most of their sports shows for example). The device also can make the picture turn over like a page in a book, do somersaults, twist, backflips, squash & expand the picture, etc, the list of effects is almost limitless. Quite a nifty piece of equipment. (One TV show that uses a lot of these effects is Hey, Hey it's Saturday).

-RACECAM Control (Located at the helipad) - This site was in control of all the Racecam functions. They spoke to the drivers & commentators, controlled the movement of the cameras themselves & also directed the relay chopper. Only one racecam at a time was available. The output was fed to Downstream control. The Racecam cars each had a microwave uplink which was received by the relay chopper. The chopper was needed for relay of signals due to the hilly terrain & trees, etc that severely attenuate the microwave signals & a ground receive station would not be able to provide a good continuous signal. The chopper selected one uplink signal to its downlink transmitter, which was tracked from the grounds of the Hargraeves House Welfare Home, opposite the racetrack. This was also the tracking point for the ATN camera chopper. This chopper also had an uplink receiver which received Racecam No:1 (Mustang) & transmitted this instead of the picture from the camera in the chopper. This allowed two Racecam cars to be switched "back-to-back". The output of the tracking receivers was linked back to the main site, where each was fed to framestore synchronisers. These devices are necessary so that the picture doesn't roll or jump when put on air. Racecam cameras 1 & 2 were controlled by radio telemetry signals radiated from Racecam Control at the Helipad. Racecam 3 was a fixed wide-angle CCD camera. The Racecam director had radio communication with Racecam 1 & 2, & co-ordinated the commentators & drivers' two way conversations. Last year saw a world first when ATN linked up the Racecam car of Dick Johnson (driving a Ford Mustang & running fifth at the time) to the America's Cup yacht Kookaburra II, being skippered by Ian Murray. The set-up & technology involved in this feat would take another page to explain, but in short this achievement required two new pieces of equipment. An AUSSAT Satellite with a transportable earth station & a seagoing Racecam which was waterproof & internally stabilised by a gyroscope. This offered dramatic shots of the yacht's angle to the horizon as it keeled over in the windward legs.

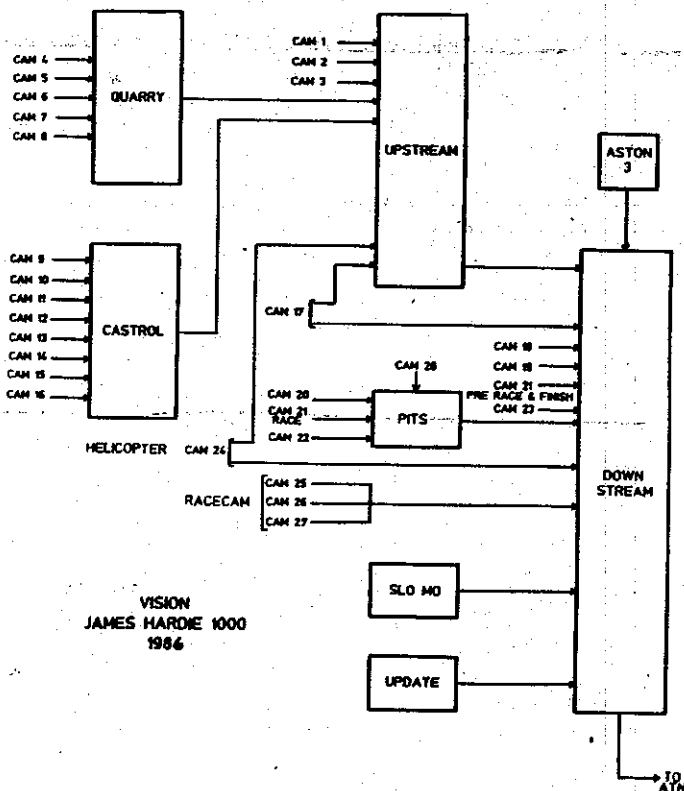

VISION  
JAMES HARDIE 1000  
1986

### Camera Descriptions

Camera Position	Type	Lens	Van
1 Pit Camping Area-40' scissor lift	Mk8	15x	Upstream
2 Murray's Corner-scaffold	Mk8	15x	Upstream
3 Hell Corner-4' scaffold	Mk8	15x	Upstream
4 GTX Bend-12' scaffold	HL79	30x	Quarry
5 BP Cutting - trackside	HL79D	17x	Quarry
6 Winfield Corner - trackside	HL79D	13x	Quarry
7 Quarry - 12' scaffold	HL79	17x	Quarry
8 Reid Park - 6' scaffold	HL79	17x	Quarry
9 Castrol Curve - 6' scaffold	Mk8	15x	Castrol Tower
10 McPhillamy Park - trackside	Mk9	15x	Castrol Tower
11 Skyline - trackside	Mk9	15x	Castrol Tower
12 Dipper (top) - trackside	Mk8	15x	Castrol Tower
13 Dipper (bottom) - trackside	330P	14x	Castrol Tower
14 Esses - trackside	Mk9	15x	Castrol Tower
15 Forest Elbow - trackside	Mk9	15x	Castrol Tower
16 Conrod (top) - 2' scaffold	330P	30x	Castrol Tower
17 Windsor's Gate - crane	BVP-3	7x	Upstream
18 Ampol/Dunlop roof	HL79E	30x	Downstream
19 VIP Stand - roof	Mk8	15x	Downstream
20 Pit Row - mobile	HL79E	14x	Pits
21 Pit 24 - interview/mobile	HL79E	14x	D'stream & Pits
22 Pit 24 - interview	HL79E	17x	Pits
23 Pit straight	HL79A	17x	Downstream
24 ATN Choppercam	BVP-3	17x	Upstream
25 Racecam 1	BVP-3	7x	Downstream
26 Racecam 2	BVP-3	7x	Downstream
27 Racecam 3	CCD	W/A	Downstream
28 Pit Row - Linked Mobile	BVP-3	14x	Pits



**NEWTEK-  
ELECTRONICS**

WE STOCK:  
ALARMS - ANTENNAS  
BOOKS - BOXES  
COMPONENTS-COMPUTERS  
HARDWARE - KITS - TOOLS  
WIRE AND A LARGE RANGE  
OF SEMICONDUCTORS FOR  
THE PROFESSIONAL AND  
HOBBYIST : 116 CORRIMAL  
STREET WOLLONGONG.  
(JUST FROM HARP-HOTEL)  
PHONE : 27 1620.

**DON'T BE CAUGHT OUT ON**

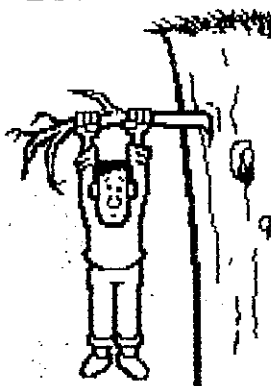

A LIMB LIKE HIM.

**GET**

INTO YOUR CLUB  
LOTTO FUND  
RAISER

**NOW.....**

A MOTHER mouse and her baby were scampering across a back veranda when suddenly they heard a noise. A big black cat was bearing down on them, much too close for comfort.

Mother Mouse turned towards the cat and shouted "Bow-wow!"

The cat fled down the back yard.

Clutching her baby, Mother Mouse said, "Now, my child, that will show you how important it is to learn a second language."

**COAST-WIDE  
COMMUNICATIONS**

LOT.B. LAWRENCE -  
HARBOR DRIVE, THIRROUL

WE STOCK: CB RADIOS  
CB AERIALS - COAX CABLE  
MARINE RADIOS  
TV - AERIALS, ETC ETC.  
SALES AND SERVICE

OPPOSITE THE  
SHELL - GARAGE  
PHONE : 67 2134.

VK2KWN WAYNE NEWPORT

**BEHIND THE SCENES (CONTINUED)**

The final programme (minus commercials) from ATN OB 1 Downstream Control was fed back to the ATN studios at Epping by terrestrial microwave links at Yetholme & Blackheath. Also a Telecom bearer from the main site was used as a back-up path back to ATN. From the ATN studios the programme is distributed to other stations by microwave bearers & AUSSAT. Another bearer was used to from ATN back to Mt. Panorama to provide an "On-Air" signal so that the site knew what was actually going to air. A UHF television transmitter at the main site radiated this signal around the track for the vans at the Quarry & Castrol Tower & to all the cameras around the track, so that they could hit a button a see for themselves what was actually going to air.

The whole set-up is all very simple when you think about it! So when your next sitting in your comfy chair watching the race coverage, spare a thought, (if only a small one), to the huge amount of technology & man-power required to provide you the viewer, with an interesting programme.

Till next time, 73 de VK2MT

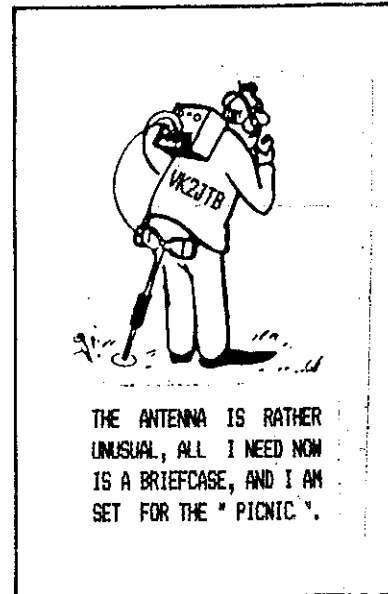
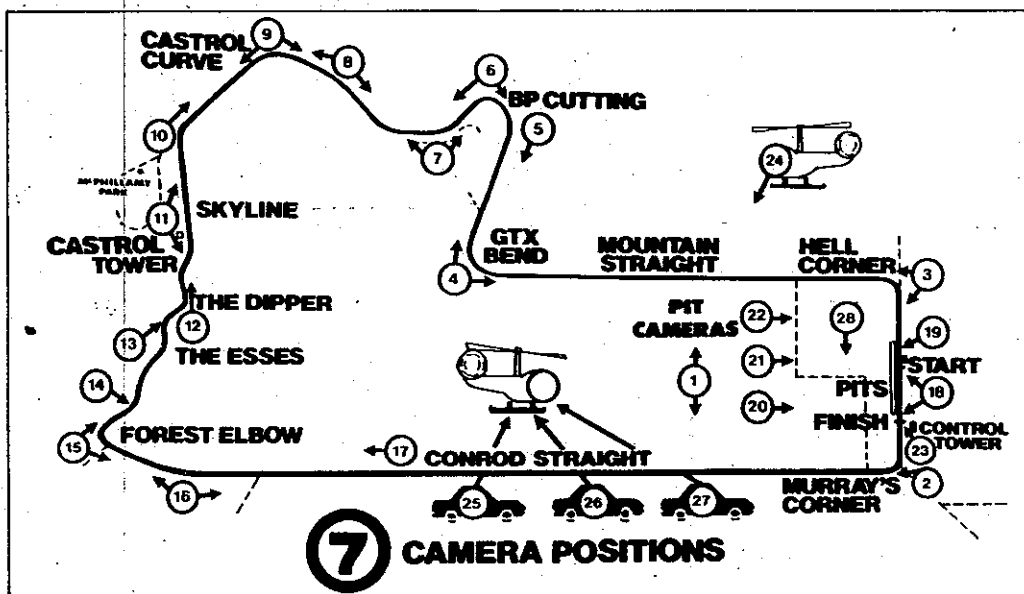



# ABOUT YOUR FRIENDS

VK2EXN (Ian) suffered a severe heart attack on the 11th September only 10 days after his 57th Birthday.

He was admitted to Port Kembla Hospital and put in the intensive care ward. He was kept in this ward until the 19th, when he was then transferred to the rehabilitation ward.

It was from this ward (which has now been renamed "shack ward") that Ian's itinerary was as follows:-

Saturday night:  
C.Q. Calls on 438.225

Sunday morning:  
Contacts on 70 cm.

Missed WIA  
broadcast through  
hospital QRM.

Sunday evening:  
Listened to WIA  
broadcast on 2 m.

Came up on 2m  
during call backs.

And received lots  
of Good Wishes from all  
those on the band.

All this plus  
finding time for  
treatment and visits  
from his wife Lola and  
also his son and club  
members, well done Ian.

Another one of our  
fraternity who had to go  
into hospital recently  
was VK2 QU (Jim).

Jim kept an  
appointment on the 24th  
September for more check  
ups on his heart  
condition, we hope  
everything went well for  
you Jim.

Best wishes from  
all club members.

Dave VK2VAV/YKQ announced that his next overseas trip will commence on 21/11/87 and it will consist of a flight to Sweden, a crossing of USSR by the Trans-Siberian railway and travel through Tibet to China.

This will be followed by a trip down river of about a week and a lecture tour of some Chinese colleges.

All in all pretty hectic stuff, but fairly normal to our intrepid treasurer.

-----\*\*\*\*-----

Paul VK2DZJ in Hospital also. Paul also has been whisked off to Wollongong Hospital for an urgent gallstones operation and we extend our wishes for a quick recovery.

-----\*\*\*\*\*-----

New Callsigns were announced for two members. Chris Sesmores is now VK2XHW and Mark

Wilson is now VK2AZZ.

Congratulations are in order for one of our members, its for quiet spoken VK2 JCV Col.

Col has passed his exam and has been upgraded to full call and his new callsign is VK2 FJE. What better way to congratulate you Col than to call you, "THE QUIET ACHIEVER".

KEEP THIS DATE FREE..

The Club XMAS PARTY will be held at Cordeaux Dam on 13th December 87 Hope to see you all there.

-----\*\*\*\*\*-----

VK2 EMI Reg and his XYL Margaret will shortly be returning from their long holiday touring around North Queensland.

Reg has made various contacts back into the Illawarra area during his trip, and word has it that he went slightly berserk while on holiday shooting everything in sight.

Yes Reg took his video camera along with him so looks like we might have a film showing on his return.

Hope you had a trouble free trip Reg and hope to see you back soon at the club meetings.

**WOLLONGONG  
ALUMINIUM  
CENTRE**

Available Ex Stock a Range of  
ALUMINIUM:-

- \* Rectangular Hollows.
- \* Round Hollows.
- \* Square Hollows.
- \* Flat Bars.
- \* Channels.

\* Cutting Service Available \*

All at COMPETITIVE WHOLESALE  
PRICES. Suitable for building  
your own antennas.

Situated At :-  
79 Gipps St; WOLLONGONG  
Located close to railway  
crossing.  
Phone: 299382 or 285932.

The Museum is going to relocated the AMATEUR RADIO STATION VK2BQK from the POWER HOUSE MUSEUM to the NEWCASTLE REGIONAL MUSEUM.

This is a new MUSEUM under construction and is located in an old brewery in Hunter St. Its main core of interest lies in the Industrial heritage of the Hunter region.

It is not clear at this point just when the amateur radio station will be re-activated.

As with most major projects, there are a

number of construction stages to the Newcastle museum with staggered completion dates.

Where the station fits into the scheme of things is still not quite known as yet.

It is a pity that it had to leave the Power House Museum, as most interested overseas visitors would have had a lot better chance to see it while passing through Sydney. At least it will be displayed.

Westlakes Radio Club have elected a 7 man committee to Co-ordinate the establishment of the radio exhibit. Westlakes have also said they have

17 Amateurs showing willingness to operate the station when complete.

Also let us hope that manufacturers will be again be loaning modern radio equipment for this display.

Taken from WINTER AREWISE. 1987.

### AUSSAT 3

Aussat 3 has been successfully launched on the French ariandne vehicle. This was a sweaty palms launch as the Nasa Challenger and two ariadne vehicles had all failed to achieve orbit resulting in some extensive re-design.

\*\*\*\*\*

 <p>THERE ONCE WAS A HAM WHO WAS SO THIN HIS PANTS KEPT FALLING DOWN</p>	 <p>SO HIS XYL FED HIM WITH LOTS OF CREAM CAKES.</p>	 <p>AND SOON HE WAS BIG, BIG, BIG. HE GOT SO BIG HE COULDN'T FIND ANY TROUSERS TO FIT HIM</p>	
	<p>SO OUR POOR OLD HAM TOOK UP SPORT AND WEIGHT LIFTING. AFTER A WHILE HE STARTED TO LOSE SOME WEIGHT.</p>	 <p>HE GOT THINNER AND THINNER UNTIL HE WAS ONLY</p>	 <p>A SKELETON OF HIS FORMER SELF.</p>
 <p>HIS XYL WHO ONCE WELCOMED HIM WITH OPEN ARMS</p>	 <p>NOW LOOKED ON OUR POOR HAM WITH HORROR.</p>	<p>SO LADIES IF YOU HAVE A HAM, REMEMBER THAT WELL KNOWN PROVERB :-</p> <p>THE NEARER THE BONE THE SWEETER THE MEAT.</p> <p>BY UK2PZY(DAVE)</p>	

# Fido's fishing fling ends in doghouse

Everybody has probably had one of those days when they should have stayed in bed. A keen fisherman from the Illawarra Radio Society recently had one experience he would much rather forget.

It seems our man was champing at the bit to try a new fishing spot he had been told about. Though wifey advised against it, he loaded up the vehicle and set out with his faithful canine companion one day of dodgy weather.

Things started going wrong when the turn-off proved elusive, but after a detour or two, he got himself (hopefully) on to the right track.

Around this time, a stake put paid to a tyre. The spare, naturally, was flat as the proverbial pancake. No problem, thought our man - he had two of those portable, battery-operated compressors to pump up the spare.

Only trouble was, one of them was broken into several parts with the rough ride it had been getting and the other just went out in sympathy.

Gritting his teeth, and prepared for any emergency, our bushman got out the hand pump and spent 30 minutes huffing and puffing until the spare was indeed fully inflated and fitted on the vehicle.

What more could go wrong? Plenty: some way down the track a bog snared the truck. Stepping out to inspect his plight, our hero was surprised to find just how extensive the bog was and fell face first into a mud hole.



However, fishermen are used to such setbacks and this fellow is renowned for his tenacity even amongst that odd breed. After much work and profane language, he was back on the road again in search of the elusive hot spot.

Finally he was there. He rigged up and leaned the rod against the truck while he surveyed the situation carefully.

When he turned back to fetch his rod - lo - he beheld his faithful Fido firmly attached to the line by virtue of having taken a fancy to the bait and swallowed it, hook and all.

The hound, realising its plight and somewhat startled by the bellow of rage and surprise from its master, promptly bolted into the scrub trailing the rod behind it with our hero in hot pursuit.

Eventually, the dog was caught and pacified, though still not too happy about the hook in its innards and line dangling from its mouth.

It was all too much - quivering and trembling, dripping mud, gasping from exhaustion and gnashing his teeth in pure frustration, our intrepid fisherman decided to call it a day and take the well caught canine into the nearest veterinary surgeon.

Later, cowed and beaten, he had to face his wife with the sorry tale and weather her wrath at being presented with a vet's bill for \$250. He was promptly placed in the doghouse himself and apparently had plenty of time to ponder the error of his ways while in purgatory.

Never mind mate - it could've happened to anybody, but we're sure glad it didn't happen to any of us.

\*\*\*

## F.R.L.No:3 WINNERS

Week NO: 9 K. Curle.  
Week No: 10 G. Parsons.  
Week No: 11 C. Lacey.  
Week No: 12 F. Brown.  
Week No: 13 P. Ball

# THE ILLAWARRA AMATEUR RADIO SOCIETY. INC.

P.O. BOX. 1838. WOLLONGONG. 2500. N.S.W.

**MEETINGS:** Are held every 2nd Tuesday of the Month except January, at 7.30 pm. in the S.E.S. Headquarters, Montague street, North Wollongong.

**REPEATERS:**  
 VK2RAW - 146.850. - (VOICE) VHF Mt Murray.  
 VK2RAW - 147.575. - (PACKET) VHF Mt Murray.  
 VK2RIL - 147.275. - (VOICE & R.T.T.Y) VHF Sublime Point.  
 VK2RUW - 438.225. - (VOICE) UHF Hill 60 Port Kembla.  
 VK2RIL - 438.725. - (VOICE & R.T.T.Y) UHF Sublime Point.

**BROADCAST:** On Sunday evening prior to the club meeting, at 7.00 pm. R.T.T.Y. Mode, and at 7.15 pm. on voice. Transmitted on 147.275 VHF, and relay on 3.562 Mhz. Callbacks will be taken after the voice broadcast.

**W.I.A. RELAY:** On 146.850. at 11.00 am. and at 7.30 pm. each Sunday.

**CLUB - NETS:** On 3.562 Mhz. SSB on Sunday at 8.00 pm. and a slow morse net on 28.440 Mhz on Thursday evenings at 8.00 pm.

**NEWSLETTER:** "THE PROPAGATOR", published Monthly to reach FINANCIAL-MEMBERS in the week preceeding the club meeting. All articles, adds etc, to the editor must be in, or try, by the 3rd Tuesday each month.

**MEMBERSHIP:** The Secretary, I.A.R.S. Inc, P.O.Box.1838. Wollongong. 2500. Full membership is \$10 per annum; students & pensioners concessional members \$5 per annum.

**AWARDS:** The Award of the Illawarra Amateur Radio Society. Inc. is the LAWRENCE-HARGRAVE-AWARD. VK stations require 10 contacts with I.A.R.S. members. Overseas stations require 5 contacts with I.A.R.S. members. A contact with VK2AMW is sufficient for the award. Band-details, date, frequency, station worked and \$2 or 4 I.R.C.'s to THE AWARD-MANAGER, I.A.R.S. Inc, P.O.Box. 1838. WOLLONGONG. 2500. No QSL-CARD is required.

**STORE:** The club store operates at each club meeting. by COMMITTEE-MEMBERS.

**COMMITTEE:**

**PRESIDENT:** VK2DYU- BILL CHADBURN. 45 Beltana Ave, Dapto.  
**VICE-PRESIDENT:** VK2OB - KEITH CURLE. 24. Beach Drv, Woonona.  
**SECRETARY:** VK2JTB- TOM BROWN. 10. O'Keefe Cr. ALBION - PARK.  
**TREASURER:** VK2VAV-YKQ-DAVE HENDERSON. 8. Gladstone st. Bellambi.

**GENERAL-COMMITTEE:** VK2MT, - ROB MCKNIGHT, VK2BIT - Peter Woods, VK2XCC/PHD - RAY BALL.

**REPEATER - CHAIRMAN:** VK2XGJ - JOHN SIMON.

**REPEATER - COMMITTEE:** VK2CAG - GRAEME DOWSE, VK2EXN - IAN CALLCOTT, VK2EMV - MORRY v.d. VORSTENBOSCH. VK2DFK-MIKE KEECH, VK2MT-ROB MCKNIGHT, VK2BIT-PETER WOODS, VK2TPH-PHIL HOWCHIN, VK2XGJ-JOHN SIMON, VK2FCP-FRED BROWN.

**QSL-CARD'S OUT :** VK2EXN - IAN CALLCOTT.

**QSL-CARD'S IN :** VK2BIT - PETER WOODS.

**PUBLICITY - OFFICER:** VK2VAV/YKQ - DAVE HENDERSON

**BROADCAST - OFFICER:** VK2ENX - TONY MOWBRAY. VK2ALU LYLE PATISON.

**CARTOONIST :** VK2AXI - BRIAN WADE.

**PROPAGATOR-EDITORS :** VK2JT - JOCK TAYLOR, VK2EMV - MORRY v.d. VORSTENBOSCH, VK2PZY - DAVE CAPON.

**PRINTERS :** VK2DFK - MIKE KEECH. AND POSTED BY VK2BIT - PETER WOODS.

**SOCIAL-DIRECTOR :** VK2XCC/PHD - RAY BALL. D.O.C. LIASION VK2OB - KEITH CURLE.

**CANTEEN-MANAGER :** VK2DYU - BILL CHADBURN.

**LIFE - MEMBERS :** VK2CAG-GRAEME DOWSE. VK2OB-KEITH CURLE. VK2ALU-LYLE PATISON

**SUNDAY - EVENING - CLUB-NET - ROSTER:**

FIRST SUNDAY OF THE MONTH : VK2MT - ROB MCKNIGHT.  
 2nd SUNDAY OF THE MONTH : VK2ENX - TONY MOWBRAY.  
 3rd SUNDAY OF THE MONTH : VK2PZY - DAVE CAPON.  
 4th SUNDAY OF THE MONTH : VK2PHD - RAY BALL.  
 5th SUNDAY OF THE MONTH : VK2EBI - KEVIN MURPHY.  
 And on stand-by : VK2DUF - GRAEME PARSONS.